



# The Dart Densifier

The Dart Densifier has been designed to reduce the amount of space necessary for storing and transporting foam foodservice products to a recycling facility. The high densification rate compresses loose recyclables to a fraction of their original size.

The end product is a densified cylinder about 15 inches in diameter and 15 inches tall, weighing about 40 pounds. As an example, it would take approximately 8,000 eight ounce foam cups to comprise one cylinder.

## Basic Operation of the Densifier\*

**1**

Put clean polystyrene into the densifier through the front-loading hopper doors.

**2**

When the hopper is full, close the hopper doors and press the green "START CYCLE" button to begin densification.

**3**

After the densification cycle has been started, the piston will move forward through the hopper. When the piston has compressed the material in its path, it will automatically return back to its original position, letting more material drop down into its path. The piston will continue to cycle forward and back, compressing material in its path, until a preset count setting is reached or until the hopper is empty.

**4**

When enough hopper loads of material have been densified to create a finished cylinder, the green "UNLOAD" light will illuminate.

**5**

When the green "UNLOAD" light is illuminated, pull up on the latch release pin, swing the latch away, then swing the end cap wide open.

**6**

Cover the open end of the cylinder with an appropriate plastic bag (Dart No. BR2).

**7**

Press the "UNLOAD" button to start pushing the finished cylinder out into the waiting plastic bag.

\*These excerpts are intended to briefly describe the operation of the Dart densifier. They are not intended to substitute for a complete reading of the Densifier Operating and Maintenance Manual.

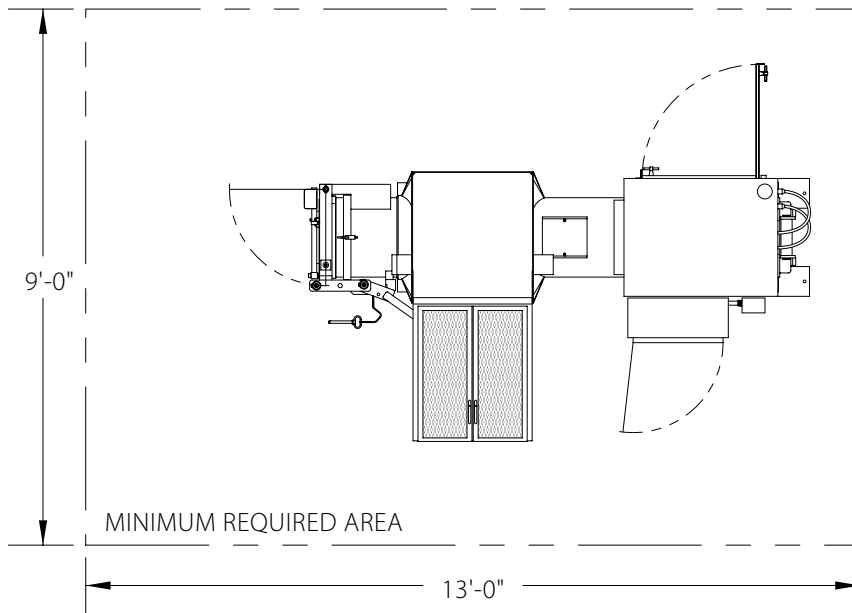

## Features

- Extra High Density Output
- Large Hopper
- Low Noise Operation
- Automatic Cycle Controls
- Safety Interlocked –  
Densifier Will Not Operate  
with Hopper Doors Open
- Heavy-Duty Construction
- Easy to Handle Cylinder
- Indoor/Outdoor Locations

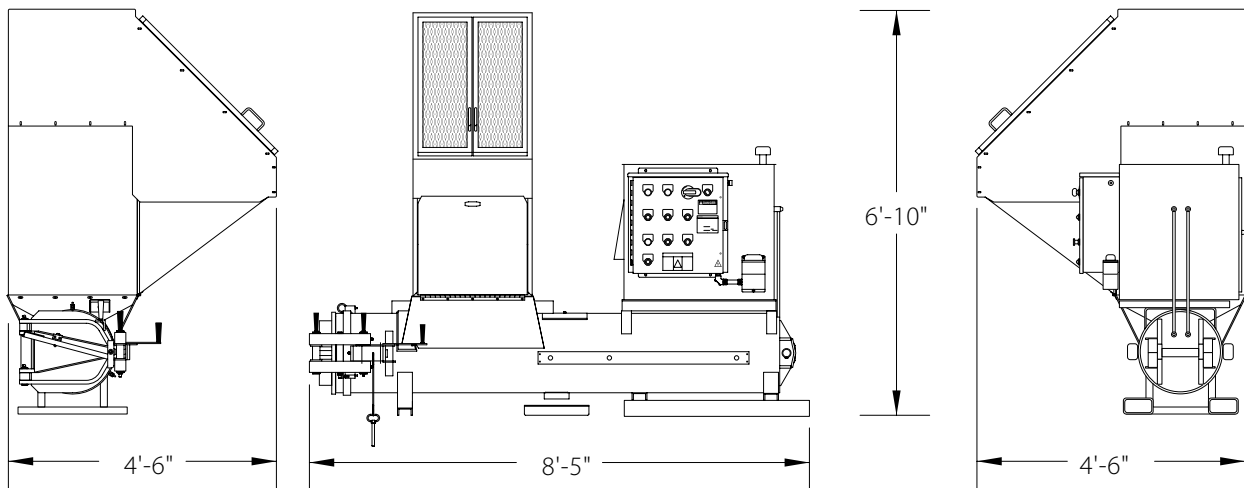

<b>Densifier Specifications</b>	
Densifier Weight (approx.)	2200 lbs
Densifier Height	6' 10"
Minimum Floorspace	13' x 9'
Electrical Service Requirements*	480 VAC, 30A or 230 VAC, 35A — 3 phase 60 Hz
* Several alternative electrical services are available at no additional cost. Contact your Dart representative for details.	
Capacity (Loose)	130 ft <sup>3</sup> /hr
<b>Densified Cylinder Specifications</b>	
Densified Foam Cylinder Weight (approx.)	40 lbs
Densified Foam Cylinder Dimensions (approx.)	15.5" dia x 15" tall
<b>Densifier Maintenance Schedule</b>	
Weekly	cleaning, inspection, and safety check
Monthly	lubrication and inspection
Annual	inspection; replace hydraulic fluid and filter
<b>Cylinder Storage Bag Specifications</b>	
Densified Foam Cylinder Bag Dimensions	30" layflat x 36" long
Densified Foam Cylinder Bag Thickness	3 mil
Densified Foam Cylinder Bag Material	Multi-layer nylon 6 and EVA (ethylene-vinyl acetate) copolymer film

Water supply and floor drain are strongly recommended for densifier cleaning purposes.

Densifier installation requires a fork lift and loading dock.

For questions on densifier installation, operation, or electrical service requirements, call 800-248-5960 and ask for Dart Densifier Service.

## **DART CONTAINER CORPORATION**

*The Industry Standard of Excellence*

Mason, Michigan 48854 U.S.A.  
Ph: 800-248-5960 • Fax: 517-676-3883  
Email: sales@dart.biz • www.dart.biz